

## BRUSELAS



## INSTALAÇÃO



1,5 h



2 operador/es



2,00 x 0,12 x 1,00 m



45 kg / 45 kg

## DADOS TÉCNICOS

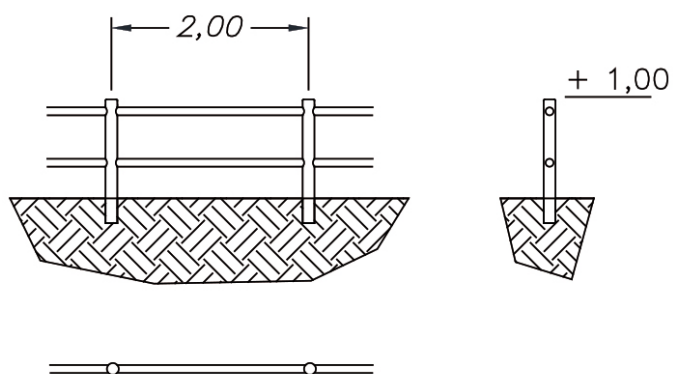

JOLAS reserva-se o direito de alterar sem aviso prévio as informações contidas neste documento.