

## BADALONA

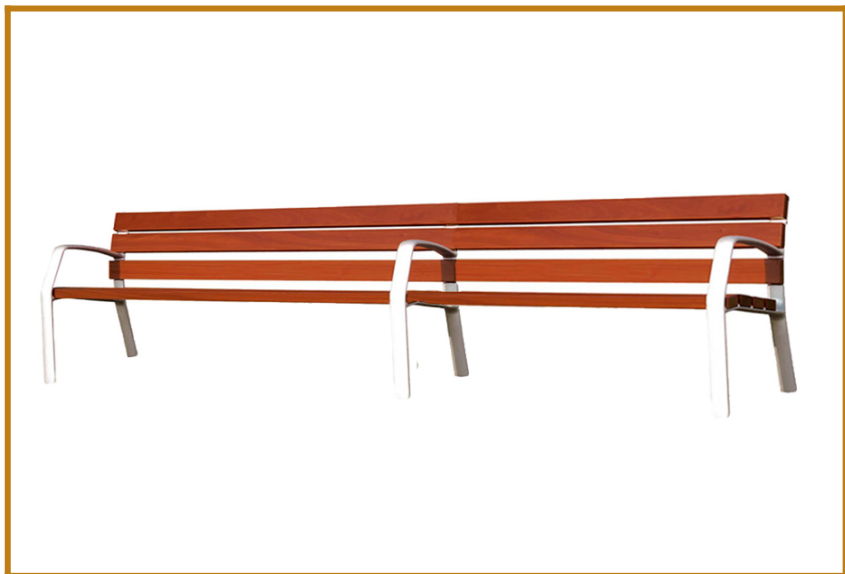

## INSTALAÇÃO



1,5 h



2 operador/es



3,00 x 0,624 x 0,773 m



74 kg / 74 kg

## DADOS TÉCNICOS

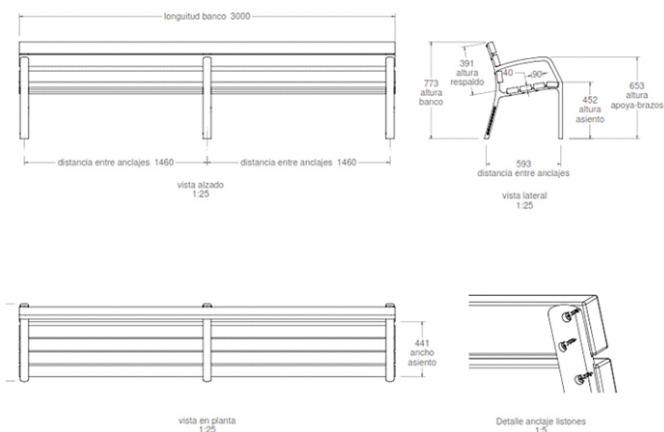

JOLAS reserva-se o direito de alterar sem aviso prévio as informações contidas neste documento.