

GALDIANO



INSTALLATION



1,5 h



2 opérateurs



2,00 x 0,14 x 1,05 m



45 kg / 45 kg

DONNÉES TECHNIQUES

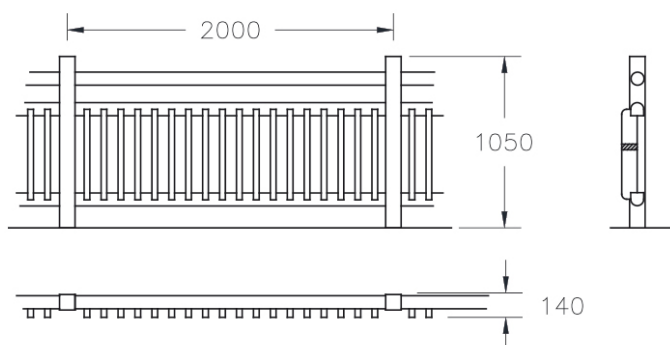

JOLAS se réserve le droit de modifier sans préavis les informations contenues dans le présent.