

BADALONA

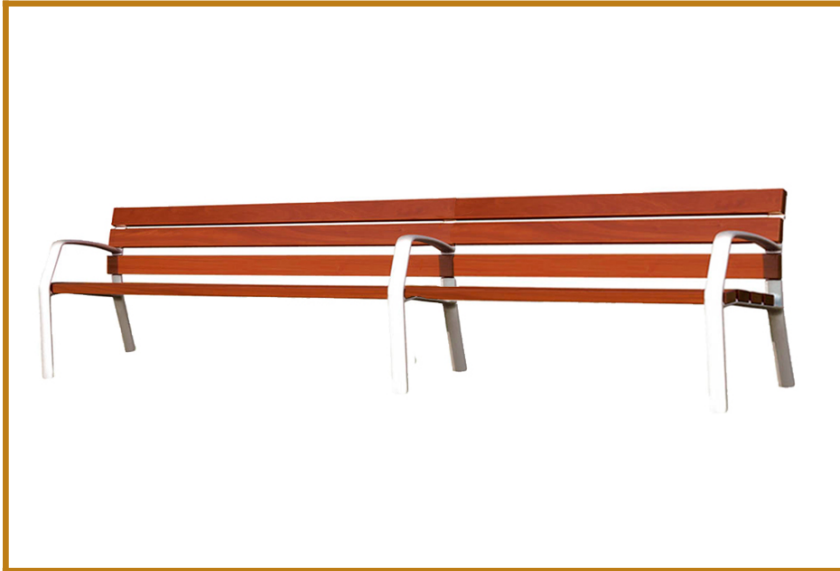

INSTALAZIOA



1,5 h



2 operadore



3,00 x 0,624 x 0,773 m



74 kg / 74 kg

DATU TEKNIKOAK

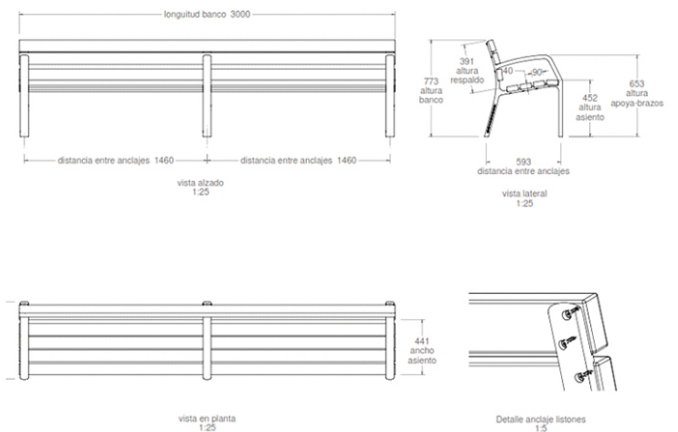

JOLAS-ek dokumentu honetan jasotako informazioa aldez aurretik abisatu gabe aldatzeko eskubidea gordetzen du.